

JUNIOR BAKED GOODS

Division 900

ENTRIES:

- **Entry Forms Accepted through Saturday, August 7, 2010 by 5 PM.**
- Entry Fee: \$.30 for 12 years & up
- No Entry Fee for 11 years and under
- **NEW: Limit 6 Items per class**
- Exhibits to fair on Wednesday, September 1st between 1 – 7 PM
- Exhibits picked up on September 6, 8 PM or September 7, 8-12 Noon

RULES AND INFORMATION:

- Limited to residents of Mariposa County and Eastern Madera County (east of Madera Canal).
- Judging will be closed
- Unless otherwise specified, all entries in this division shall be home prepared by exhibitor.
- Styrofoam display trays and cake rounds will be provided by fair.
- Bring Pie in whole; two (2) slices will be cut. One for judging and one for display. Exhibitor may than take pie home.
- **NO refrigerated items**

AWARDS

- Danish System of Judging
- Cash awards offered: For 12 & Up 1ST \$2.00 2Nd \$1.50 3RD \$1.00

BAKED GOODS

<u>11 & UNDER</u>	<u>12 & UP</u>	<u>DESCRIPTION</u>
1	2	Biscuits, 4
3	4	Bread, quick, ½ loaf
5	6	Bread, yeast, ½ loaf
7	8	Brownies, 4
9	10	Cake, 2 layers, frosted, ½ cake
11	12	Candy, 4
13	14	Coffee Cake, ½ cake
15	16	Cookies, bar, 4
17	18	Cookies, drop, 4
19	20	Cookies, no bake, 4
21	22	Cookies, rolled, 4
23	24	Cookies, other, 4
25	26	Cupcakes, frosted, 4
27	28	Muffins, 4
29	30	Pie, describe
31	32	Any Other, 4



TABLE SETTING

EACH ENTRY WILL CONSIST OF ONE SETTING. TABLE SPACE IS APPROXIMATELY 30" X 30". IF FRESH MATERIALS ARE USED THEY ARE TO BE MAINTAINED BY EXHIBITOR THROUGHOUT THE FAIR. WHILE THE WRITINGS OF ETIQUETTE AUTHORITIES WILL BE USED AS GUIDELINES, CUSTOMS TYPICAL OF ENTERTAINING IN THE WEST WILL BE ACCEPTED.

INCLUDE MENU WITH DISPLAY

<u>11 & UNDER</u>	<u>12 & UP</u>	<u>DESCRIPTION</u>
33	34	Exhibitor's Choice

Continued on next page

PEANUT BRITTLE COOKIES

11 & UNDER

35

¾ cup
¾ cup
1 cup
½ cup
2
2 cups
1 tea
1 tbs
1 cup

12 & UP

36

Brown Sugar
Sugar
Butter or Margarine
Chunky Peanut Butter
Eggs
Flour
Salt
Baking Powder
See's Peanut Brittle (crushed)

1. Cream together brown sugar, sugar and butter. Add peanut butter and eggs (one at a time). Mix together well. In a separate bowl, sift flour, salt and baking powder.
2. Mix the dry ingredients into the creamed mixture. Add the crushed See's Peanut Brittle. Roll dough into small balls, flatten with a fork and place on a greased cookie sheet. Bake at 350 degrees for 15 minutes.

JUNIOR CLOTHING, ACCESSORIES & HOME FURNISHINGS

Division 910

ENTRIES:

- **Entry Forms Accepted through Saturday, August 7, 2010 by 5 PM.**
- Entry Fee: \$.30 for 12 years and older
- No Entry Fee for 11 years and younger
- **NEW: Limit 6 Items per class**
- Exhibits to fair on Friday, August 20 between 4-7 or Saturday, August 21 between 1 –5 PM
- Exhibits picked up on September 6, 8 PM or September 7, 8-12 Noon

RULES AND INFORMATION:

- Limited to residents of Mariposa County and Eastern Madera County (east of Madera Canal).
- Judging will be closed.
- Items entered in this division must be fabric or yarn and sewn, knitted, crocheted, etc. See Crafts for items that are glued, decorated, tie-dyed, etc.
- Each entry shall have been sewn or constructed by the exhibitor in the 12 months prior to fair.
- Exhibits shall be cleaned and pressed. All knitted or crocheted items shall be blocked. Articles may have been worn, but soiled items showing excessive wear will be disqualified.
- **DEFINITIONS:**
 - *Picture* is framed with screw eyes and wire, ready to hang.
 - *Wall hanging* is unframed but has a usable hanger
 - *Quilt* is a hand or machine pieced face on a thin batting that is stitched by hand or machine and may be hand tied.
 - *Comforter* is pieced or whole faced, has a thicker batting and is hand tied and or stitched by machine.

AWARDS

- Judging: Danish System of Judging
- Cash awards offered: For ages 12 & Up 1st \$2.00 2nd \$1.50 3rd \$1.00

Continued on next page

WEARING APPAREL AND ACCESSORIES
SEWN, KNITTED, CROCHETED OR OTHER NEEDLECRAFT

<u>11 & UNDER</u>	<u>12 & UP</u>	<u>DESCRIPTION</u>
1	2	Apron
3	4	Athletic Wear
5	6	Blouse or Shirt
7	8	Doll Clothes
9	10	Dress, one piece
11	12	Pants, long
13	14	Shorts
15	16	Skirt
17	18	Sweatshirt, t-Shirt or Other Top, decorated
19	20	Two-piece outfit
21	22	Coordinated outfit, 3 pieces or more
23	24	Other wearing apparel
25	26	Other accessory

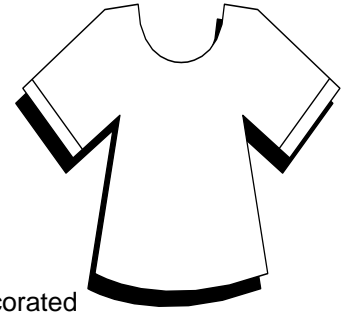

HOME FURNISHING ITEMS

SEWN, KNITTED, CROCHETED OR OTHER NEEDLECRAFT

<u>11 & UNDER</u>	<u>12 & UP</u>	<u>DESCRIPTION</u>
27	28	Afghan, describe
29	30	Blanket, doll or baby
31	32	Comforter
33	34	Hot Pads, set of 2
35	36	Picture, embroidered, crewel, needlepoint, etc.
37	38	Pillow
39	40	Placemats, set of 4
41	42	Quilt, machine pieced, machine quilted
43	44	Wall Hanging
45	46	Any Other Home Furnishings Item

JUNIOR CRAFTS & COLLECTIONS

Division 920

ENTRIES:

- **Entry Forms Accepted through Saturday, August 7, 2010 by 5 PM.**
- Entry Fee: \$.30 for 12 years and older
- No Entry Fee for 11 years and younger
- **NEW: Limit 6 Items per class**
- Exhibits to fair on Friday, August 20 between 4-7 or Saturday, August 21 between 1 - 5 PM
- Exhibits picked up on September 6, 8 PM or September 7, 8-12 Noon

RULES AND INFORMATION:

- Limited to residents of Mariposa County and Eastern Madera County (east of Madera Canal).
- Judging will be closed.
- Each entry shall have been made or produced by the exhibitor in the 12 months prior to fair, EXCEPT collections, and not shown in a previous Mariposa County Fair.

AWARD:

- Judging: Danish System of Judging
- Cash awards offered: For 12 & Up 1ST \$2.00 2ND \$1.50 3RD \$1.00

Continued on next page



COLLECTIONS

MAXIMUM DISPLAY AREA OF 18" X 24". COLLECTION REQUIRING MORE SPACE MUST BE APPROVED BY FAIR MANAGEMENT BY 8/7/10. EXHIBITOR TO SET UP DISPLAY. **COLLECTION MUST BE IN OR ON ITS OWN DISPLAY PLATFORM AT TIME OF RECEIVING.** SAME COLLECTION MAY BE ENTERED ONLY ONCE UNLESS MODIFIED OR CHANGED BY EXHIBITOR.

LIMIT: TWO COLLECTIONS PER EXHIBITOR

<u>11 & UNDER</u>	<u>12 & UP</u>	<u>DESCRIPTION</u>
1	2	Animals
3	4	Books, same theme
5	6	Button Jar, jar filled with buttons, may be decorated
7	8	Cards or Stickers
9	10	Coins or Stamps
11	12	Dolls
13	14	Rocks or Shells
15	16	Toy Cars
17	18	Wearable Items, minimum of 10 items attached to a clothing item
19	20	Any Other Collection

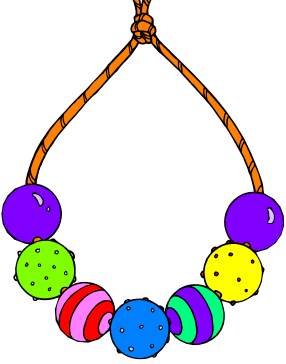
CRAFTS AND HOBBIES

21	22	Beadwork	
23	24	Book or Binder Jacket Art	
25	26	Candle	
27	28	Cascarones	
29	30	Ceramics	
31	32	Christmas	
33	34	Collage, maximum 11" x 17"	
35	36	Construx Craft	
37	38	Crayon Melt Art	
39	40	Cut Paper Craft	
41	42	Decorated Garment	
43	44	Decorated Rock	
45	46	Decoupage	
47	48	Doll	
49	50	Doll House	
51	52	Duct Tape Art	
53	54	Dream Catcher	
55	56	Foil Art	
57	58	Fly Fishing	
59	60	Garden Art	
61	62	Jewelry, not beadwork	
63	64	Leatherwork	
65	66	Lego Block Craft, must be mounted on sturdy base no more than 2 inches larger than craft	
67	68	Magnets, set of 2	
69	70	Mobile	
71	72	Model	
73	74	Nature Craft	
75	76	Needle Craft	
77	78	Paper Mache	
79	80	Pine Cone Craft	
81	82	Plaque	
83	84	Popsicle Stick Craft	
85	86	Recycled Item	
87	88	Sculpture	
89	90	Stained Glass	
91	92	Sunglasses, decorated	
93	94	Stationery, 2 sheets	
95	96	Wall Hanging	
97	98	Wood Burning,	
99	100	Yarn Craft	
101	102	Any Other	

Continued on next page

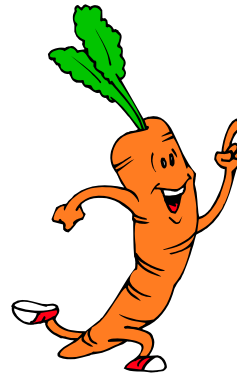
11 & UNDER1
3
5
7
9
11
13**12 & UP**2
4
6
8
10
12
14**VEGETABLES**
DESCRIPTIONBeans, snap or wax, 6 pods
Cantaloupe, 1
Carrots, 1
Chard, Swiss, 3 stems
Cucumbers, 1
Eggplant, 1
Herb, 3 stems in vase or jar**11 & UNDER**15
17
19
21
23
25
27
29
31
33**12 & UP**16
18
20
22
24
26
28
30
32
34**DESCRIPTION**Onions, 1
Parsley, 6 stems
Pepper, 1
Potatoes, 1
Pumpkin, 1
Squash, 1
Tomato, 1
Tomato, cherry, 3
Watermelon, 1
Any Other not listed, 1**FRUIT**

35

36

Any Fruit, 1

NATURE'S NOVELTIESFOR GRAND AND GROSS GARDEN GOODIES.
JUDGED ON SIZE AND/OR UNIQUENESS**11 & UNDER**37
39
41
43
45**12 & UP**38
40
42
44
46**DESCRIPTION**Corn, tallest stalk
Pumpkin
Squash
Sunflower, head with 5 inches of stalk.
Largest diameter head retaining at least 95% of seed
Other Novelty**JUST FOR FUN**47
49
5148
50
52Tallest Weed
Decorated Melon
Fast Food from the Garden-Container with ready to eat produce

JUNIOR MECHANICAL SCIENCE

Division 940

ENTRIES:

- **Entry Forms Accepted through Saturday, August 7, 2010, by 5 PM**
- Entry Fee: \$.30 for 12 years and older or as noted
- No Entry Fee for 11 years and younger
- **NEW: Limit 6 Items per class**
- Exhibits to fair on Friday, August 20, between 4-7 PM or Saturday, August 21 between 1 – 5 PM
- Exhibits picked up on September 6, 8 PM or September 7, 8-12 Noon

RULES AND INFORMATION:

- Limited to residents of Mariposa County and Eastern Madera County (east of Madera Canal).
- **NEW:** Must be finished product
- Judging will be closed
- Exhibits shall be the product of exhibitor as a regular part of their instruction in 4H or FFA industrial arts for the past year. For non 4H or FFA members, exhibits must have been completed in the 12 months prior to the fair. Items that have been exhibited at a previous Mariposa County Fair are not eligible.

AWARDS

- Judging: Danish System of Judging
- Cash awards offered: For ages 12 & Up 1ST \$2.00 2ND \$1.50 3RD \$1.00

JUNIOR MECHANICAL SCIENCE PROJECT

NOT 4H OR FFA
DESCRIBE ITEM AND SIZE ON ENTRY BLANK

<u>11 & UNDER</u>	<u>12 & UP</u>	<u>DESCRIPTION</u>
1	2	Mechanical Science Project
3	4	Woodworking Project

4-H MECHANICAL SCIENCE PROJECT

DESCRIBE ITEM AND SIZE ON ENTRY BLANK

5	6	4H Small engines project
7	8	4H Small engine group project
9	10	4H Woodworking project
11	12	4H Other mechanical science project

FFA AGRICULTURAL MECHANICS

CHAPTER PROJECTS OR PROJECTS BY MORE THAN ONE STUDENT MUST BE SO IDENTIFIED.

SMALL PROJECTS, CONSTRUCTED NOT OVER \$15.00

<u>CLASS</u>	<u>DESCRIPTION</u>
13	Acetylene Welding
14	Arc Electric Welding
15	MIG or GMAW Welding
16	Sheet Metal
17	Welding and Forging
18	Wood
19	Any Other

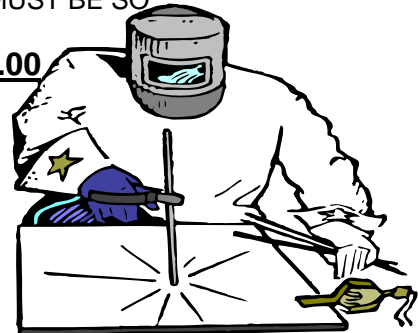

Continued on next page

FFA MEDIUM PROJECT, CONSTRUCTED

\$16 - \$150

ENTRY FEE: \$.50 PER ENTRY

Cash Awards: \$2-1.5-1

- 20 Sheet Metal
- 21 Welding
- 22 Wood
- 23 Any Other, not listed

FFA LARGE PROJECT, CONSTRUCTED

\$151 - \$750

ENTRY FEE: \$1.50 PER ENTRY

Cash Awards: \$15-10-5

- 24 Any Large Project

FFA EX-LARGE PROJECT, CONSTRUCTED

\$751 AND OVER

ENTRY FEE: \$2.50 PER ENTRY

Cash Awards: \$25-15-10

- 25 Any Extra Large Project

JUNIOR PAINTINGS & DRAWINGS

Division 950

ENTRIES:

- **Entry Forms Accepted through Saturday, August 7, 2010, by 5 PM**
- Entry Fee: \$.30 for 12 years and older
- No Entry Fee for 11 years and younger
- **NEW: Limit 6 Items per class**
- Exhibits to fair on Friday, August 20 between 4-7 PM or Saturday, August 21 between 1 – 5 PM
- Exhibits picked up on September 6, 8 PM or September 7, 8-12 Noon

RULES AND INFORMATION:

- Limited to residents of Mariposa County and Eastern Madera County (east of Madera Canal).
- **NEW:** Judging will be closed.
- All work must have been completed by the exhibitor within the 12 months prior to opening day of fair and not shown at a previous Mariposa County Fair.
- EXHIBITS MUST BE READY TO HANG AS FOLLOWS:
 - 1) Paintings and drawings are to be mounted on construction paper or poster board which is approximately 1-2 inches larger than the drawing. No double thickness of mounting paper/board. Corners of mount paper/board will be pinned or stapled to display area.
 - 2) Framed and ready to hang with screw eyes and wire. **NO GLASS**

AWARDS:

- Judging: Danish System of Judging
- Cash awards offered: For ages 12 & Up 1ST \$2.00 2ND \$1.50 3RD \$1.00

Continued on next page

FAIR THEME ART

Work to depict theme of the Mariposa County Fair

“A Big Time in a Small Fair”

<u>TO 6 YEARS</u>	<u>7-11 YEARS</u>	<u>12 & UP</u>	<u>DESCRIPTION</u>
1	2	3	Theme Drawing
4	5	6	Theme Painting

DRAWINGS

ENTER NAME OF DRAWING ON ENTRY BLANK

7	8	9	Cartoon Drawing
10	11	12	Chalk
13	14		Coloring Book Picture
15	16	17	Computer Art
18	19	20	Computer Graphics
21	22		Crayon Drawing
23	24		Finger Painting
25	26	27	Pen and Ink, black
28	29	30	Pencil, plain, animal
31	32	33	Pencil, plain, other
34	35	36	Pencil, colored
37	38	39	Pen, colored
40	41	42	Pointile
43	44	45	Drawing done as part of an art class
46	47	48	Any Other Drawing

PAINTINGS

ENTER NAME OF PAINTING ON ENTRY BLANK

<u>TO 6 YEARS</u>	<u>7-11 YEARS</u>	<u>12 & UP</u>	<u>DESCRIPTION</u>
49	50	51	Acrylic
52	53	54	Oil
55	56	57	Paint by Number
58	59	60	Tempura
61	62	63	Watercolor
64	65	66	Painting done as part of art class
67	68	69	Any Other Painting



JUNIOR PHOTOGRAPHY

Division 960

ENTRIES:

- **Entry Forms Accepted through Saturday, August 7, 2010 by 5 PM**
- Entry Fee: \$.30 for 12 years and older
- No Entry Fee for 11 years and younger
- **NEW: Limit 6 Items per class**
- Exhibits to fair on Friday, August 20 between 4-7 PM or Saturday, August 21 between 1 – 5 PM
- Exhibits picked up on September 6, 8 PM or September 7, 8-12 Noon

RULES AND INFORMATION:

- Limited to residents of Mariposa County and Eastern Madera County (east of Madera Canal).
- Judging will be closed.
- All work must have been completed by the exhibitor within the 12 months prior to opening day of fair and not shown at a previous Mariposa County Fair.

DISPLAY GUIDELINES:

- Enlargements must contain a minimum of more than 35 square inches of picture. 5"x7" is 35 square inches.
- Snapshots: must contain a minimum of 3" x 5" (15 square inches) or a maximum of 4" X 6" (24 square inches)
- All enlargements and snapshots to be mounted on white poster board or mounting board measuring 10" tall and 8" wide (tall is vertical, wide is horizontal).
- Due to display area limitations, mounting board must not deviate from stated size. No double mount boards.

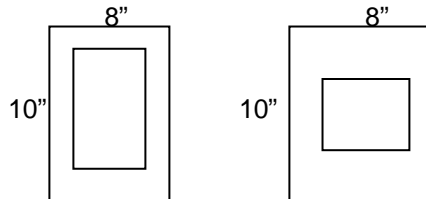

AWARDS

- Judging: Danish System of Judging
- Cash awards offered: For ages 12 & Up 1ST \$2.00 2ND \$1.50 3RD \$1.00

PHOTOGRAPHY

<u>11 & UNDER</u>	<u>12 & UP</u>	<u>DESCRIPTION</u>
1	2	Snapshot, animal
3	4	Snapshot, human
5	6	Snapshot, landscape
7	8	Snapshot, action
9	10	Theme, "A Big Time in a Small Town"
11	12	Digitally Manipulated Photo
13	14	B & W Enlargement
15	16	Color Enlargement

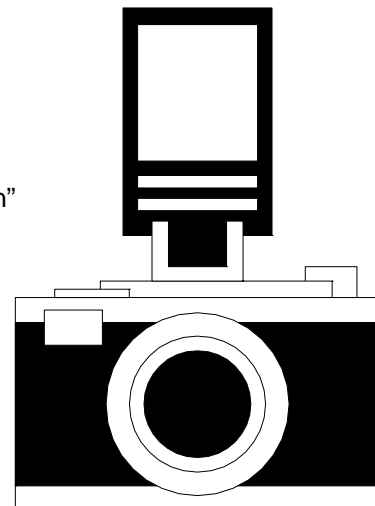

JUNIOR PLANTS & FLOWERS

Division 970

ENTRIES:

- **Entry Forms Accepted through Saturday, August 28, 2010 by 5 PM**
- No Entry fee for ages 11 & Under
- Entry Fee: \$.30 for ages 12 & Up
- **NEW: Limit 6 Items per class**
- Exhibits to fair on Thursday, September 2nd between 1-7 PM
- Exhibits picked up on September 6, 8 PM or September 7, 8-12 Noon

RULES AND INFORMATION:

- Limited to residents of Mariposa County and Eastern Madera County (east of Madera Canal).
- Judging will be closed.
- Each entry shall have been made or produced by the exhibitor. Exhibitors are solely responsible for the care and watering of all exhibits.

AWARDS

- Judging: Danish System of Judging
- Cash awards offered: For ages 12 & Up 1st \$2.00 2nd \$1.50 3rd \$1.00

POTTED HOUSE PLANTS

<u>11 & UNDER</u>	<u>12 & UP</u>	<i>DESCRIPTION</i>
1	2	Leafy Plant
3	4	Flowering Plant
5	6	Cactus or Succulent
7	8	Hanging Basket
9	10	Other Potted Plant



ORNAMENTAL/LANDSCAPE PLANT

ONE OR FIVE GALLON CONTAINER OR AS NOTED

11	12	Ornamental, in bloom
13	14	Shrub
15	16	Evergreen
17	18	Deciduous

NOVELTY GARDENS

19	20	Dairy Box Garden, recycle milk, cottage cheese, yogurt, etc. container.
21	22	Magical Sponge Garden, sow seeds in a sponge
23	24	Water Rooted Plant, carrot, potato, avocado, etc.
25	26	Unusual Container, use a shovel, scoop, dustpan, boot, rock, shell, etc, describe

DRY OR ARTIFICIAL ARRANGEMENTS

ALL ARRANGEMENTS MUST BE ON A MOUNTING BOARD FOR DISPLAY PURPOSES

27	28	Easter Bonnet
29	30	Tool Belt
31	32	A Diller a Dollar
33	34	Time after Time
35	36	Thyme and Time
37	38	"A Big Time in a Small Town"

FRESH ARRANGEMENTS

39	40	Hats Off
41	42	Saddle Up
Q	44	Indian Summer
45	46	"A Big Time in a Small Town"

JUNIOR PRESERVED FOODS

Division 980

ENTRIES:

- **Entry Forms Accepted through Saturday, August 7, 2010 by 5 PM**
- Entry Fee: \$.30 for 12 years and up.
- No Entry Fee for 11 years and under
- **NEW: Limit 6 Items per class**
- Exhibits to fair on Wednesday, September 1st between 1 – 7 PM
- Exhibits picked up on September 6, 8 PM or September 7, 8-12 Noon

RULES AND INFORMATION:

- Limited to residents of Mariposa County and Eastern Madera County (east of Madera Canal).
- Judging will be closed
- Exhibitor MAY bring two identical jars for each entry if they wish. If two jars are brought, one will be opened and judged; the other will be displayed during the fair. Jars that have been judged may be picked up on Thursday, September 3rd after the judging has been completed.
- All entries in this division must have been preserved by the exhibitor within one year of the opening day of fair. Items which have been shown at any previous Mariposa County Fair are not eligible. All products which have not been eliminated from consideration will be opened.
- Standard canning jars must be used. Standard jars are a container specifically designed for canning purposes. NO PARAFFIN SEALS. All canning must be in sealed jars.
- All non-acid foods must be canned UNDER PRESSURE.

AWARDS:

- Judging: Danish System of Judging
- Cash awards offered: For 12 & Up 1ST \$2.00 2ND \$1.50 3RD \$1.00

To promote the art of pickling foods and safe home food preservation BALL® and KERR® home canning products. Best of Category, Soft Spreads, 1st and 2nd place prepared using Ball pectin and in a Ball or Kerr jar/lid. UPC from fruit jell package must accompany entry. 1st and 2nd place in each category of fruit, vegetables, pickled foods and soft spreads using Ball or Kerr jar/lid

<u>11 & Under</u>	<u>12 & UP</u>	<u>DESCRIPTION</u>
1	2	Canned Fruit
3	4	Canned Vegetable
5	6	Dehydrated Food
7	8	Fruit Leather
9	10	Jam or Jelly
11	12	Jerky
13	14	Pickles
15	16	Sauce
17	18	Trail Mix
19	20	Any Other

LOCAL RULES FOR EXHIBITING

1. Entry forms will be accepted on a first come, first serve basis.
2. Entry blanks may be brought to the office of the fairgrounds or mailed directly to 5007 Fairgrounds Road, Mariposa, CA 95338
3. Responsibility for proper completion of entry blank rests with exhibitor, not with fair staff. BE sure your name, complete mailing address, county and zip code are clearly printed on the entry form. Any premium monies awarded will be mailed to the address on the entry form.
4. Check the DIVISION and CLASS numbers carefully with the Exhibitor Handbook before listing on the entry blank. Do not enter items under ANY OTHER classes when a class is provided for that item.
5. Wrong information appearing on entry forms may lead to disqualification. No exhibit will be judged unless all discrepancies are cleared within 24 hours of judging.
6. State Rules: 2010 State Rules are available in the fair office. If you would like a copy please come by the fair office and ask for a copy. State Rules are also available on the web site at www.cdfa.ca.gov/fe
7. Entries are made under the name/ownership of ONE EXHIBITOR unless specified for a class eligible for "group" entry.
8. If the check or the entry fee is refused by the bank, a penalty of \$25.00 per check must be paid before judging the class (es) entered.
9. LIMIT OF TWO SUBSTITUTIONS PER DIVISION. In livestock, substitutions may be made prior to and up to the time the animal is brought to the fairgrounds but not after that time. NO SUBSTITUTIONS OF STILL EXHIBITS WILL BE ACCEPTED AFTER ENTRY BLANK IS TURNED INTO FAIR OFFICE.
10. Insurance coverage (personal property and liability) for exhibits is at the sole discretion of the exhibitor. The fair association affords no such coverage. Liability insurance for livestock/small animal exhibitors is available through the California Fairs Services Authority. Contact the Fair Office for more information. **NOTE: All Animal Exhibitors in the Junior Department are required to either provide proof of liability insurance or purchase it from CFSA through the fair office.**
11. All materials and decorations must be made from a non-flammable material or be treated and maintained in a flame retardant condition. The State Fire Marshal will make an inspection before the opening of the fair and may make additional inspections during the fair. Materials not flameproof will be condemned and removed from the fairgrounds. Exhibits or booths having deficiencies written up by the fire marshal will not be judged. Unless all items have been corrected.
12. FOR SALE signs, business cards or other forms of advertisement will **NOT** be allowed on any still exhibit entered in competition for premiums or ribbons.
13. Exhibitors may not write on or alter the information as printed on the Exhibitor Tag provided by the fair. Any discrepancies must be cleared with the fair office. See Building Supervisor for information.
14. Exhibitors may be disqualified and/or dismissed from the show for not giving proper attention to their articles or animals both during the fair and at the close of the exhibition. Exhibitors not caring for their animals after the auction may be disqualified from showing the fair the following year.
15. Exhibitors must conduct themselves in a safe and proper manner while on the fairgrounds. Exhibitors involved in inappropriate or unsafe behavior on the fairgrounds before, during or after the fair dates, are subject to dismissal from the show at the discretion of fair management. For example, driving recklessly on the grounds, failure to care for or improper treatment of animals and other inappropriate behavior as determined by fair management. Decision of fair management is final.
16. All exhibits must be removed from the Fairgrounds at the times specified at the beginning of each division. Exhibits other than livestock may be carried out beginning at 8 PM, Monday (last day of Fair). Exhibitors may not drive onto the grounds to pick up exhibits until such time as determined by fair management. See Division headings for livestock release times. Any exhibit not picked up on specified date (s) becomes the property of the Mariposa Fair.
17. Animals left more than 24 hours after close of fair will be turned over to the local animal control officer. Still exhibits left more than seven working days after close of the fair will be disposed of by fair management.
18. Grounds and office will close promptly at 12 Noon on Tuesday (day after the Fair). The fair is not responsible for items not picked up during the specified times. Exhibitors should make arrangements with another person to pick up items if they will be unable to do so personally.
19. Claim checks must be presented when picking up exhibits.
20. Exhibits removed from the grounds prior to stated release times will not be eligible for any premiums won at the fair.
21. Animals not under the complete control of the exhibitor, which in the opinion of fair management, staff or directors, are hazardous to the public safety shall be disqualified and removed from the fairgrounds.
22. All prizes will be paid on a uniform basis. The 35-A District Agricultural Association will not assume any responsibility for typographical errors.
 - A. Exhibitors in Danish classes are limited to two highest cash awards. L

Continued on next page

23. *Sponsored items must be received by fair office before competition begins. All sponsored awards must be approved by the Mariposa Fair board of Directors at their July meeting. Awards donated after that time will not be accepted. Sponsored cash and trophies are not paid from Fair funds.*
24. Checks for premiums and other cash awards will be prepared as soon as possible and, barring any unforeseen circumstances, no later than 28 days after fair closes. Exhibitors may pick up their checks at the fair office or they will be mailed at the end of 28 days. CHECKS MUST BE CASHED WITHIN SIX MONTHS AFTER THE DATE OF ISSUE OR THE CHECK WILL BE NULL AND VOID.
25. Best of Show will be awarded to first place winners only. Champion and Reserve Champion market animals will be selected from Market Ready animals only or Group 1 animals.
26. Paper ribbons may be exchanged for silk ribbons at the fair office until September 30, 2010.
27. The 35-A District Agricultural Association (Mariposa County Fair) is required by the Internal Revenue Service to report any premiums paid of \$600.00 or more. Exhibitors will be asked for Social Security number on entry blanks or may be asked to complete a Form W-9.

LOCAL RULES FOR PROTESTS

- Protests will be considered only if there has been a violation of State or Local Rules. Decisions of judges, official fair veterinarians, weigh masters; timers and flaggers cannot be protested and are final. All questions concerning competition or non-protest able disputes or differences shall be referred to fair management or designee whose decision is final.
- All protests must be presented to the management of the fair in writing within 24 hours of the alleged violation and must be accompanied by a \$100.00 deposit (\$200.00 if the protest relates to violations of animal health rules) in the form of cash, money order or certified check. Protests of still exhibits must be made within 48 hours of the official opening of fair. The deposit will be returned if the protest is upheld.
- Fair management will respond, in writing, within 24 hours receiving a protest.
- A minimum of five members (quorum) of the Board may hear and decide a protest. The protest will be heard in a timely manner considering requirements of the Bagley-Keene Open Meeting Laws.
- If protests cannot be resolved with the Board of Directors, the matter may be appealed to the Division of Fairs and Expositions.

LIVESTOCK

28. Entry blanks for 4H project work are required to have the signatures of the Community Club Leader and the Project Leader. Proper signatures for all 4H, FFA, Grange and Independent entries must be included on the entry blank.
29. The required management records for independent livestock/small animal exhibitors are available at the fair office. These records must be available during check in time for review by fair management and/or livestock superintendent.
30. Junior age exhibitors who are helping other junior exhibitors must be entered and showing in junior classes at this fair. Exception: 4H, FFA, Grange or Independents sharing the same barn area, pen, etc. may share feeding of their club/chapter animals. First offence will result in disqualification of exhibitor from participation in showmanship classes. Second offence will result in disqualification of exhibitor from entire show including the auction
31. Weight certificates signed by the fair's official weigh master shall be completed for each animal entered in divisions for market and feeder livestock classes categorized by weight. The weighing shall be conducted by the official weigh master at the times specified in the Exhibitor's Handbook. EXHIBITOR MAY REQUEST ONE RE-WEIGH. EXHIBITOR AND ANIMAL MAY NOT LEAVE THE SCALE AREA WHILE THE SCALE IS BEING BALANCED. No animal shall be admitted to the scale that is obviously fatigued or stressed or shows symptoms of attempt to alter the weight of the animal. Such attempts are grounds for dismissal from the show.
32. After weighing, market animals will be divided into weight lots within the weight limitations as desired by the management for convenience in judging.
33. No animal sold in the Junior Livestock Auction will receive premium monies.
34. All entry agreements of all livestock and small animal exhibitors contain a certificate of animal medication. By signing the entry agreement, the exhibitor certifies that no unauthorized chemicals have been used which would cause the carcass to fail USDA and Food and Agriculture Administrative Standards; and that the withdrawal time required of any medication, including medicated feeds, or pesticide administered has been adhered to. In addition, the exhibitor certifies that he/she is responsible for his/her animals if it is rejected at a processing center due to the presence of drug residues. If drug residue is detected, the exhibitor may be liable to the buyer for the amount equal to three times the purchase price, attorney's fees and civil penalties.

Continued on next page

35. If there is a complaint or allegation of illegal substances regarding a particular animal, fair manager will contact the processor and advice. If an animal tests positive for banned substances the exhibitor will be prohibited from showing any market animal at the Mariposa County Fair for the following three years. In addition the Division of Fairs and Expositions will be notified.
36. By signing the entry blank, exhibitor certifies to the best of their knowledge that the animals entered in the fair are not being treated for or been exposed to any communicable disease within 30 days prior to the fair. If such exposure occurs after entry deadline, exhibitor agrees to advise fair management, cancel said entries and refrain from bringing exposed animals to the fair.
37. Release and Waiver of Liability. By signing the agreement for entry, exhibitor acknowledges voluntary participation in the fair; that he/she is aware that activities with livestock, including horses, are hazardous and assume all risks of bodily injury, death or property damage; and hold harmless the fair and the State of California for any injury or damage resulting from participation in the fair.
38. All animals brought to the fair for exhibit must be in show condition, in good health and shall not have been exposed to any communicable disease. Fair management reserves the right to determine whether or not an animal is in proper show condition when it arrives at the fairgrounds and to dismiss any animal determined not to be in good show condition or in good health. Decision of fair management is final.
39. Animals must be fed, watered, cleaned and otherwise completely cared for no later than 9:00 AM each morning of the fair. Failure to do so may result in dismissal from the show and/or disqualification from participating the following year.
40. Exhibitors are responsible for providing all equipment needed to care for animals on exhibit including feeders, waterers, cooling fans, etc.
41. Information on registration papers must match entry blank by time of judging or animal will not show. No papers pending entries will be judged.

LIVESTOCK EXHIBITOR PASSES AND PARKING

- Exhibitors in the open livestock department (beef, sheep, dairy goats & boer goats) will receive one parking pass plus gate admission passes as follows:
 - 1-5 head.....1 season pass
 - 6-10 head.....2 season passes
 - 11 + head.....3 season passes
 - **MAXIMUM of three season passes per exhibitor. Exhibitor to check in their animals with the clerk at the respective barns and receive their passes after the animals have been checked in.**
 - Exhibitors in the open pigeon and poultry divisions may obtain a season pass and a parking pass by paying the difference between their entry fees and \$20.00. Exhibitors pay \$20.00 or more in entry fees will receive one season pass and one parking pass.
 - Exhibitors in the horse show will receive one day pass for each day entered and one parking pass.
 - Junior livestock and small animal exhibitors will receive one season pass regardless of number of animals entered.
 - **NO MORE THAN TWO PARKING PASSES WILL BE ALLOWED PER FAMILY.**
 - Passes that are lost or misplaced will not be replaced by the fair.
 - A limited number of spaces for RV parking in the livestock area, inside the grounds, will be available at the cost of \$100.00 per space. **NO GENERATORS TO BE RUN FROM 11 PM TO 5 AM-NO EXCEPTIONS.** These spaces will be allotted on a first come, first serve basis. Reserve space on entry blank and send camping fee with entry fees. Dry camping only. Camping site will be open on Thursday (the day before fair opens) from 10 am to 5 PM and Friday (opening day of fair) from 9 AM to 12 Noon only for parking of vehicles. Exhibitors must check in at the main office before parking.
 - Livestock will be accepted and released through the livestock entrance on Hwy 49 South. This entrance will be closed during the hours the fair is open and exhibitors will enter through the livestock entrance in the back parking lot. Exhibitor's vehicle pass will allow vehicle inside the grounds prior to 9 am during the fair. At 9 AM all vehicles must be removed from the grounds and parked in a designated area in the outside back parking lot. Any vehicles remaining after the 9 AM deadline will be towed at the owner's expense.
 - Vehicle parking pass admits only the vehicle within the grounds. Occupants of the vehicle must have either a pass or pay admission to enter.
44. All trucks, trailers and cars must be parked in areas designated by fair management. Vehicles and/or equipment parked in non-designated areas will be towed at owner's expense.
 45. First bedding will not be provided. Bedding will not be available for purchase on the grounds.
 46. **BEEF, SHEEP, SWINE AND GOATS TO BE SHOWN IN A NATURAL STATE. CLIPPING IS PERMITTED. NO ARTIFICIAL COLORING CHEMICALS, GLUE, PAINT, OIL, POWDER OR OTHER ENHANCING PRODUCT MAY BE USED. ANIMALS MAY BE WASHED PRIOR TO BRINGING THEM TO THE FAIR.**

47. **DUE TO WATER WASTE LAWS, THERE WILL BE NO WASH RACKS OR WASHING DURING THE FAIR.**
48. Animal welfare recommendations will be enforced.
49. There will be charge of \$10.00 per day (or portion of day) per head for all livestock brought to the grounds prior to Wednesday preceding the Fair.
50. Individual animals shown in group exhibits must be identified on the entry form.
51. All livestock entries must be identified as to owner and type of animal throughout the fair. Stall cards provided by the fair may be used to identify each stall and tie and may be secured from the livestock office.
52. Extension cords used by exhibitors to distribute power to electrical apparatus such as fans, clippers, etc. shall be rated 15 amps minimum and contain ground wire. Cords not meeting these requirements will be confiscated for the duration of the fair.
53. NO domesticated pets of any kind will be allowed on the fairgrounds with the exception of Seeing Eye and service dogs, exhibits and entertainment arranged by fair management. Exhibitors in violation of this policy will forfeit any premium monies won and may not be allowed to participate in future fairs.
54. Spectators outside show rings are not to talk to, assist or make noise intended to help an exhibitor during showmanship or any other class. NO coaching of exhibitors will be allowed while they show including livestock and horse show events.
55. Livestock will be released Monday evening at the times specified. Livestock Supervisor will coordinate the releasing of all animals with security.
56. Exhibitors are to keep animals in the barn to which assigned unless required to leave for weigh in, showing or selling in the auction. Exhibitors should not change stalls assigned unless approved by fair management or livestock supervisor.
57. Handlers of livestock animals (beef, sheep, swine, dairy goats & meat goats) may not be under the age of nine years old.
58. Exhibitors of open and breeding animals must have owned the animals for a minimum of 30 days prior to opening day of fair.
59. If local rules require a terminal show, exhibitor and parent agree that the animal (s) exhibited will be shipped and processed.
60. The official fair veterinarian serves the needs of the fair, I.E. animals are healthy and in the proper condition for show. **Any service that might be requested of the fair's official veterinarian by a specific exhibitor is at the sole expense of the exhibitor.**
61. The determination of the official fair veterinarian shall be made in the best interest of the animal in question and for other animals at the fair and shall prevail while the animal (s) are on the fairgrounds.
62. Independent exhibitors must file all information with the fair office at least 120 days for beef and leased horses. 60 days for sheep, swine & goats. 30 days for rabbits, poultry & pigeons.
63. **NO CAMPING IN LIVESTOCK BARNs. NO EXCEPTIONS.**

HORSE SHOW

- All riders, drivers and attendants shall be neatly and suitably dressed as specified in the exhibitor's handbook. Horse Show manager shall have the final decision.
- At his/her discretion, the judge may require a work-off for ties in individually worked competition. For ties other than in the individually worked competition where there is a work-off, the prize money is split between the winners (i.e. first and second place money is pooled and split evenly between the two riders.) Distribution of non-money awards shall be determined by management.

SCORECARDS

SHOWMANSHIP

APPEARANCE OF ANIMAL.....	40
Condition	[10]
Grooming/Clipping	[20]
Cleanliness	[10]
APPEARANCE OF EXHIBITOR.....	10
SHOWING IN THE RING.....	50
Moving or leading	[15]
Posing	[15]
Show animal to best advantage	[10]
Poise, alertness and attitude	[10]

MARKET HOG SCORECARD

Market Acceptable: U.S. No 1 and No. 2 hogs of average or greater conformation that are acceptable in leanness, muscularity and production traits.

Not Market Acceptable: Any hog of below average conformation including U.S. No. 3, U.S. No. 4 and utility grade hogs.

MARKET LAMB SCORECARD

Market Ready: USDA Prime or Choice quality with 12th rib back fat range .16-.35, average or greater conformation and cut ability.

Not Market Ready: Good or lower quality grade with 12th rib back fat range >.16 or >.35; under finished lambs grading USDA good or lower, below average cut ability or conformation. Note: Fairs may allow for additional grouping systems within the market ready lambs or Market Acceptable hogs for sale purposes.

MARKET GOAT (CHEVON) SCORECARD

Market Ready: USDA Prime or Choice quality with 12th rib back fat range .08-.12 most desirable. .13-.22 back fat acceptable, average or greater conformation and cut ability.

Not Market Ready: Good or lower quality grade with 12th rib back fat range <.08 or >.22; under finished goats grading USDA good or lower, below average conformation or cut ability.

MARKET BEEF SCORECARD

Market Ready: Market steers projected to have sufficient fat deposition to meet the marbling specifications for USDA Prime, Choice or Select+ quality grades.

Not Market Ready: Market steers lacking evidence of sufficient fat deposition to produce a desirable consumer product. Steers projected to USDA Select- or lower

POULTRY (MEAT BIRDS) SCORECARD

Conformity to breed type to be considered in judging.

SYMMETRY.....	10
CONDITION.....	10
WINGS AND SHOULDERS.....	10
BACK AND SPRING OF RIBS.....	10
BREAST-LENGTH OF KEEL.....	10
BREAST-FLESHING.....	20
LEGS-FLESHING.....	20

PEN OF THREE MEAT RABBITS SCORECARD

Meat Type.....	40
Condition of Flesh.....	25
Uniformity of Body and Weight.....	20
Fur.....	15

FEATURE BOOTH SCORECARD

Judges shall give preference to booths using natural materials in decorations and backgrounds.

Educational Value.....20

Informative value through the use of labeling, legends and any other manner in which information is conveyed to the public.

Ingenuity.....30

Cleverness and skill in design and/or contrivances used to illustrate or represent, such as miniatures, diagrams, photographs, models, etc. Should adhere to scale, inconspicuous detail not required.

Decoration and Arrangement.....15

Effective use of articles or products, color and animation which attracts attention and presents a pleasing appearance. Attractive arrangement and the proper grouping of commodities to achieve well balanced harmony. Effective use of all space allotted.

Lighting.....10

Dramatic effects, color and/or any other technique enhancing the exhibit.

Exhibit Theme.....20

Thought or idea expressed by design or feature of the exhibit. *NOTE: Booth must follow fair theme.*

Variety.....5

Number of different kinds of products displayed, bearing in mind the diversity or limitations of the area each exhibit represents. A maximum of 50 varieties will be considered in the booth. Additional varieties will count only as enhancing the overall appearance of the exhibit. Separate fruit and/or vegetable varieties shall count as additional varieties only when sufficiently mature to show individual varietal characteristics. Canned or processed products shall not be counted as additional varieties of a raw product. Judges shall deduct whenever the quantity of a product is not sufficient to display satisfactorily. Indigenous non-cultivated plants and trees or their flowers and ornamental plants shall not be counted except where flowers are a commercial crop of the area represented.

FLORAL ARRANGEMENTS SCORECARD

Design (proportion to scale, balance, form)	30
Color Harmony	20
Distinction and Originality	20
Interpretation and Adherence to Title	20
Condition	10

Accessories permitted, but emphasis should be on the creative use of floral and plant materials to symbolically represent class title, rather than excessive use of props to create scenes.

CUT FLOWERS SCORECARD

Cultural Perfection	80
Condition	20

POTTED PLANTS SCORECARD

Size/Variety	20
Form/Variety	20
Color, Substance, Texture of Bloom/Foliage	20
Grooming	10
Condition	30

FRUITS, VEGETABLES AND NUTS SCORECARD

Factors the judge considers when placing awards:

Condition: Free from insects, injury or blemish

Quality: Would bring the best financial return in the commercial market

Form: Typical of variety

Size: Desirable for commercial use

BAKED FOODS AND CONFECTIONS SCORECARD

Texture	35
Flavor	35
Appearance	30

TABLE SETTINGS SCORECARD

Correctness: Placement of plates, silver, glassware, napkin, complete menu	40
Originality	30
Overall Picture: Color balance, table cover, napkins, centerpiece, ambience	30

JAMS, JELLIES, PRESERVES, MARMALADES SCORECARD

Appearance: Color characteristic of fruit, clearness, jellies transparent. Container-glass, clean, sealed, neatly labeled. No paraffin seals. Proper size	30
Texture	35
<u>Jelly:</u> Tender, should quiver, cut easily and retain shape, no crystals	
<u>Preserves:</u> Pieces firm and whole. Clear, thick syrup.	
<u>Marmalades:</u> Small, thin pieces. Clear, thick syrup.	
<u>Butters:</u> Fruit that has been pressed through a sieve. No separation of fruit and juice.	
<u>Jams:</u> Crushed fruit. No separation of fruit and juice.	
Flavor: Characteristic, without excessive sweetness or overcooked flavor	35

PRESERVED JUICES AND SYRUPS SCORECARD

Taste (natural flavors)	40
Appearance (particularly color)	25
Texture (right thickness, no pieces)	20
Container and label	20

PICKLED FOODS SCORECARD

Container: Sealed, proper jars of specified size, clean, neatly and properly labeled	10
Appearance: Uniform color, suitable and uniform size, liquid clear with no scum, texture, firm, not shriveled from overcooking or excess salt, acid or sugar.	65
Safety and Suitability: choice of fruit and/or vegetable that is safe and suitable for home picking.	25

OPEN CLOTHING AND TEXTILES/CRAFTS SCORECARD

Workmanship: Cut on grain, seams even, suitably finished, stitching, zipper darts, hem, waistline, neckline finish or collar, sleeves or armholes, buttons or fasteners, belts, pockets, interfacing, lining, etc.	60
General Appearance: Clean, ready for display. Well pressed. Fabric/trim appropriate for style. For coordinated items, consider relationship of color, texture and style.	20

QUILTS AND QUILTED ITEMS

Visual Statement: Visual impact. Outstanding or special qualities	50
Pattern Use & Design: Balance, rhythm, design flow	10
Color	10
Construction: Points and corners meet precisely. Curves are smooth. Stitches invisible. Cross stitches going same way.	10
Quilting/Ties: Evenly spaced stitches of uniform length	10
Binding or Edge: Both sides and ends even length.	10

NEEDLEWORK SCORECARD

General Appearance: Clean, neat, ready for exhibit. Individuality of design, color and texture harmony.	40
Workmanship: Stitches even, secure. Neat, consistent direction. Thread/yarn ends joined or woven inconspicuously, secure	40
Suitability of article for purpose:	20

ARTS AND CRAFTS SCORECARD

Appearance: How does it look?	25
Workmanship: How is it made?	35
Utility: How usable is it?	20
Originality: Creative?	20

PAINTINGS AND DRAWINGS

Impact on Viewer: Catches the eye, holds attention. Originality, imagination, concept.	35
Composition: Expression, presentation of elements	35
Technique of Media and Material	20
Presentation: Mounted neatly and securely.	10

PHOTOGRAPHY SCORECARD

Impact: Effect on the viewer, storytelling quality, catches the eye, holds the attention.	25
Composition: Arrangement of the elements. Contains all the necessary elements. Contains few or no distracting or unnecessary elements. All elements are arranged to tell the story and lead the eye into the picture.	25
Technical Quality: The photograph is clear and sharp, and shows details in areas where appropriate.	25
Workmanship: Pictures are mounted neatly and securely in accordance with exhibiting requirements.	25

MECHANICAL SCIENCE SCORECARD

Appearance: Symmetry, finish, attractiveness, completeness and overall eye appeal.	25
Quality of Workmanship: Well constructed.	25
Originality: In design, decoration, ornamentation, mounting.	20
Neatness: Cleanliness, orderliness, precision.	15
Utility: Suitability for purpose intended.	15

**STATE RULES CAN BE OBTAINED AT
THE FAIR OFFICE OR ONLINE AT
WWW.CDFA.CA.GOV/FE**